

Early Learning Range

Ocha Table



The Ocha Activity Table, with built-in tote boxes for easy storage, offers a fun, practical solution for early learning spaces. Keep toys and materials organised and always within reach!

Top Options – Standard in Birch Plywood. Also available in EO Laminate, Writable and Timber finishes.

Frame Colour – Standard in Silver powder coat, upgrade colors Wedgewood, Eucalypt, and Territory.

Design – Features 150mm radiused corners for safety and aesthetics.

Tote Boxes – Available two or four removable tote boxes. Ideal for sensory play.

For more details or to enquire about specific configurations, visit the VE Furniture Ocha Activity Table page.



| Model | Description | W | D | H |
|--------|-------------------------------|------|------|-----|
| OCH005 | Ocha Activity Two Tote Table | 1200 | 1200 | 450 |
| OCH006 | Ocha Activity Four Tote Table | 1200 | 1200 | 450 |

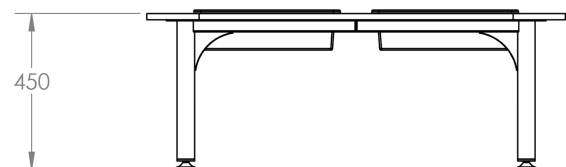
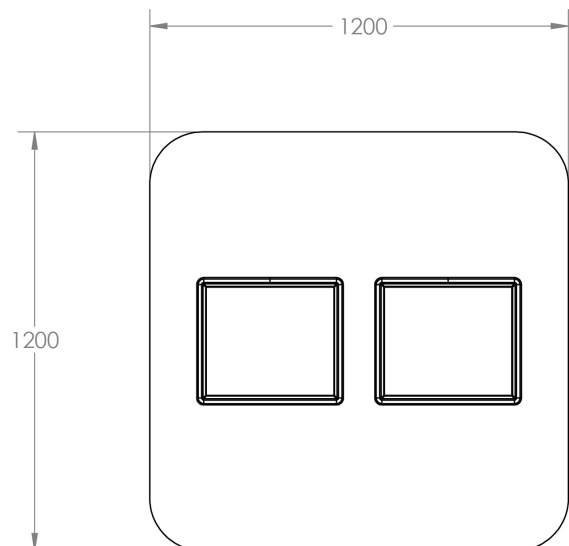

Finish Options

Ocha Table

Core Palette

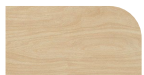

B-PLY
Birch Plywood



PC-SLV
Silver

Standard Product Finish

This product is crafted from durable birch plywood and silver powder coated steel offering a blend of natural strength and style for any learning space.

Extended Palette

EO Laminate



S-DKO
Dark Oak



S-NTO
Natural Oak



S-LTO
Light Oak

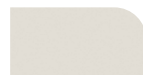

L-WHT
White



S-DNT
Dark Oak



S-PND
Natural Oak



S-BND
Light Oak



S-GRY
White



S-IRN
Ironstone



S-DMD
Diamond



S-ZNC
Zincworks



W-WRT
Writeable

Powder Coating



PC-EUC
Eucalypt



PC-TER
Territory



PC-WED
Wedgewood



PC-BLK
Black

Laminated Plywood

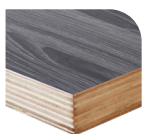

L-DKO
Dark Oak



L-NTO
Natural Oak



L-LTO
Light Oak



L-WHT
White

Tote Boxes

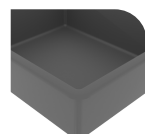

TB-STM
Storm

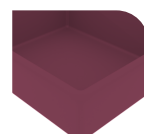

TB-CRN
Cranberry

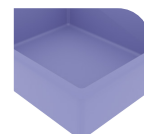

TB-GRP
Grape

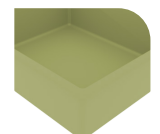

TB-APL
Apple

Want to specify a different laminate or timber?

No problem. We work with leading providers such as Laminex and Polytec and have access to their range of finishes.



TB-TNG
Tangelo



TB-TRN
Translucent

